

3-41-500-00795
DRAWING NO:

FOR TOLERANCES OF UNTOLERANCED
DIMENSIONS DURING MANUFACTURE
REFER PLANT STD.NO TP 023 0299

RETRACTED POSITION

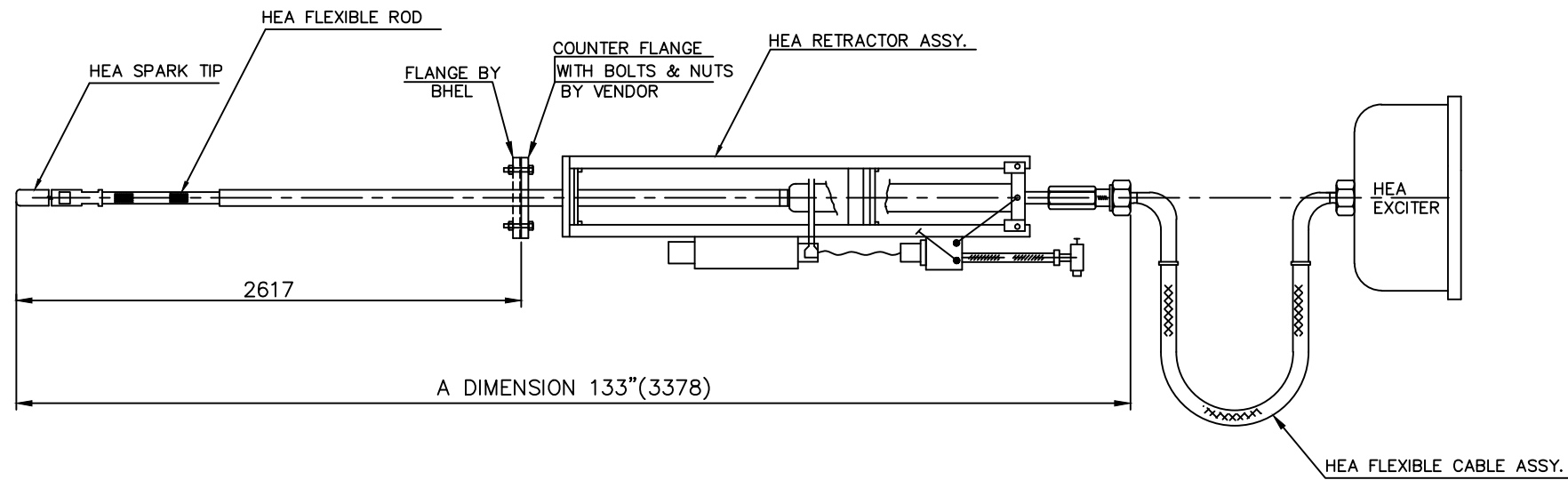



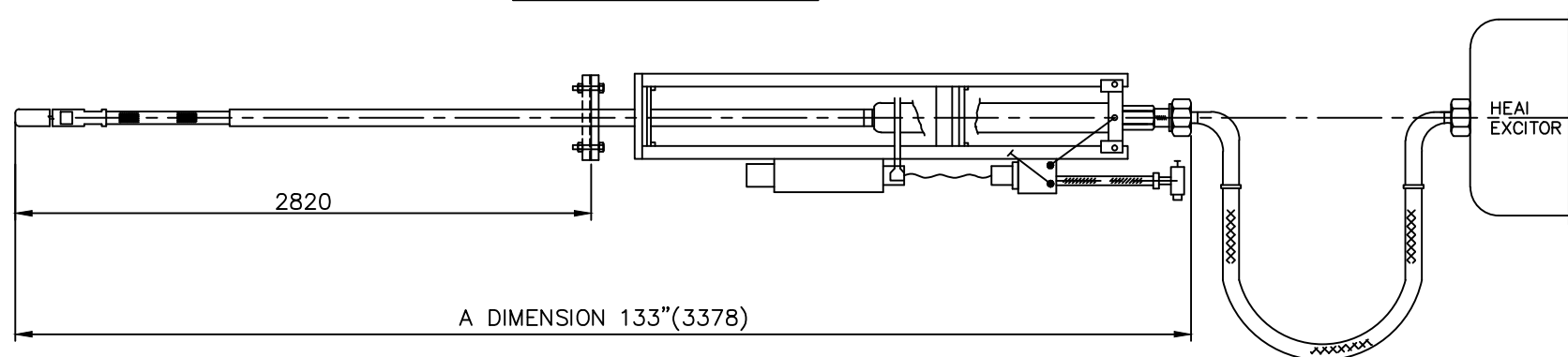

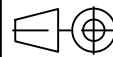
EXTENDED POSITION



CAUTION: The information on this document is the property of BHARAT HEAVY ELECTRICALS LTD. It must not be used directly or indirectly in any way detrimental to the interest of the company.	TYPE OF PRODUCT OR NAME OF CUSTOMER/PROJECT		WIDTH=32" DEPTH=2462MM			
	 Bharat Heavy Electricals Ltd UNIT: HIGH PRESSURE BOILER PLANT TIRUCHIRAPALLI - 620014 355-055		DRN	NAME	SIGNATURE	DATE
			CHD	G SARAVANAKUMAR	-sd-	24.02.2014
	APPD	M THANDAPANI	-sd-	24.02.2014		
DEPT FS(FB) CODE 129	ALL DIMENSIONS ARE IN MM	PROJECTION	SCALE	WEIGHT (Kg)	REF TO ASSY / OLD DWG	
			N.T.S	---		
TITLE					DRAWING NO :	REV
HEA IGNITOR DISPOSITION					3-41-500-00795	00



REV	DATE	ALTERED :
01		CHD & APPD:
ZONE		

PROJECT	2x660 MW UDANGUDI TPP-STAGE I
	OWNER: TAMILNADU GENERATION & DISTRIBUTION CORPORATION LIMITED 5 th Floor, Western Wing, NPKRR Maaligai 144, Anna Salai, Chennai-600002.
	OWNER'S CONSULTANT: DESEIN PRIVATE LIMITED DESEIN HOUSE, GREATER KAILASH-II, NEW DELHI
 Maharatna Company	BHARAT HEAVY ELECTRICALS LTD
TITLE	Painting schedule for Boiler components
DOCUMENT NO:	PL: C3 - PS/ 1729, Rev.01 Dated 31.08.18

	UDANGUDI 2 X 660 MW SUPER CRITICAL THERMAL POWER PROJECT STAGE-I
Category: I	APPROVED
Lr.No.CE/Projects-II/SE/C/UP/EE/M/F.UP Engg/D. /18 dt .2018.	
Approval conveyed herein neither relieves the Vendor/Contractor of his contractual obligations and his responsibilities for correctness of dimensions, materials of construction, weights, quantities, design details, assembly fits conforming to the relevant codes and standards as per the specification and performance requirements nor does it limit the purchaser's rights under the contract.	
CHIEF ENGINEER/PROJECTS-1 TANGEDCO, CHENNAI-02	



**TANGEDCO UDANGUDI SUPERCRITICAL THERMAL POWER
PROJECT, 2X660MW STAGE-I, THOOTHUKUDI DIST, TAMILNADU
CUSTOMER NO: U6/1729 & 1730, UNIT – I & II
PAINTING SCHEDULE**

Prepared by	K. Srinivasan Senior Engineer/ Plant Lab		Document No: PL: C3 - PS/ 1729
Reviewed by	S Thiagarajan AGM/ PE/ FB		Revision No: 01 Dated: 31-08-2018
Approved by	A. Santhakumari AGM / Plant Lab		Sheet No. 01 of 13

m:\chem. \contracts 15\ UDANGUDI-TANGEDCO 2X660 MW STPP\psword_00.doc

RECORD OF REVISIONS

Rev. No	Date	Details of revision	Remarks
00	25-05-2018	New	Prepared in line with bid resolutions between TANGEDCO/ FICHTNER & BHEL on BID spec No. SE/C/ UP/ EE/E/OT N0.01/2015-16, Ref: Annexure - 3, Try-Quality, 2x660MW UDANGUDI TPS, STAGE-I.
01	31-08-2018	Sl No 7 – Brush painting indicated as per comments. Sl. No. 8 - working temperature of the Items indicated in the bottom. Sl. no. 10 - Surface cleaning before galvanization is indicated. Sheet 13 - Repair procedure for damages in the painted components is included.	Modified as per comments for CAT. III approval by TANGEDCO 'Letter for comments on painting schedule of SG' Ref: Lr. No. CE/Pr-II/SE/C/UP/EE /M/AEE/M/F.Engg/D.350/18, dt. 30.08.2018.

Sl. No.	PGMA / Description	Surface Preparation & Surface Profile	Primer coat		Intermediate coat		Finish coat			Total DFT μm (min)
			Paint	No. of coats	Paint	No. of coats	Paint	No. of coats	Shade	
1 PSIAC	<u>Collector & Separator Vessels (Except Internals), Supports</u> 04 -321,323,547;	SSPC-SP3/ Power Tool Cleaning	Red Oxide Zinc Phosphate Primer (Alkyd Base) to IS 12744 DFT= 30 μm per coat	1	--	--	Synthetic Enamel paint (Long Oil Alkyd) to IS 2932 DFT= 20 μm per coat	2	International orange shade No:592 of IS 5	70
2 PSSB	<u>Collector & Separator Vessels internals and Dd items (threaded and machined surfaces only)</u> 04-347;07-302,331,361,362,393; 08-911,912,913;09-303,304;12-306,314; 12-317,324,327,328,344,348,354,393; 17-304,306,319;19-306,307;21-602,605,700; 24-352,700,803,818,827,842; 28-700;32-700;35-190,700,701;36-700; 39-700;41-710;42-700,710;43-710; 45-710;47-710;48-019,700; 65-710;67-710; <u>Foundation materials: 35-010, 39-012</u>	SSPC - SP3 Power Tool Cleaning	Rust Preventive Fluid to PR: CHEM: 09 - 04 DFT=20 μm per coat	2	--	--	--	--	--	40
3 PS19A4	<u>Buck stays</u> 07-509;08-001,003,006,007,111,380,501, 08-503,901,910; <u>Boiler supporting structures, Columns, Girders, Bracings</u> 34-100,200,300,390,400,500; 35-111,112,121,122,130,140,150,211, 212, 35-213,214,221,222,231,232,311,312,321, 35-322,331,332,341,342,351,352,361,362, 35- 381 to 387, 390, 35-441 to 447, 451 to 457, 511 to 517 35-521 to 527;35-531 to 537, 993,995;	Blast cleaning to SA2 ½ (Near white metal) with surface profile 35-50 μm	Inorganic Ethyl Zinc Silicate Primer DFT=75 μm per coat	1	Epoxy Based MIO Pigmented Intermediate Coat DFT=100 μm per coat	2	#Aliphatic acrylic Polyurethane paint to DFT 50 μm	#1	Dark admiralty Grey Shade No: 632 of IS5	325

To be applied at site

S. No.	PGMA / Description	Surface Preparation & Surface Profile	Primer coat		Intermediate coat		Finish coat			Total DFT μ m (min)
			Paint	No. of coats	Paint	No. of coats	Paint	No. of coats	Shade	
3 PS19A4 (Contd.)	<u>Galleries, Stair-ways & inter connecting Walkways</u> 36-110,130,150,311,312,313,314,315,316, 36-321,322,323,324,325,326,331,332,333, 36-334,335,336,337,338,341,342,343,344, 36-345,346,351,352,353,354,355,356,361, 36-362,363,364,365,366; 36-391 to 395 36-610,613,620,740; 38-210,299,310,381,410,510,610,611,710; <u>ID system structures.</u> 39-101,102,141,142,150,299,300,301, 39-304,305,306,993; <u>Duct supports</u> 48-015,115,145, 205,225,235,265,385, 48-435,465,485,495,665;	Blast cleaning to SA2 1/2 (Near white metal) with surface profile 35-50 μ m	Inorganic Ethyl Zinc Silicate Primer DFT=75 μ m per coat	1	Epoxy Based MIO Pigmented Intermediate Coat DFT=100 μ m per coat	2	#Aliphatic acrylic Polyurethane paint to DFT 50 μ m	#1	Dark admiralty Grey Shade No: 632 of IS5	325
4 PS3	<u>Components >95° C Insulated other than components in Sl.No.7 &9</u> Ring Headers, Down Comers, Hot air Headers outside the gas path etc. 05-155,227,231,251,327,330,350; 07-110,125,223,231,232,317; 10-174,178,191,195,274,278,283, 10-284,285, 10-291,295; 12-178,850,852,900; 15-136,178,236,278; 17-476;18-001,002,010,701; 19-701,702,903;21-600;24-811,824,828; 24-836,837;42-020,030,128,150,158;	SSPC-SP3/ Power Tool Cleaning	Red Oxide Zinc Phosphate Primer (Alkyd Base) to IS 12744 DFT= 30 μ m per coat	2	--	--	--	--	Red oxide	60

To be applied at site

Sl. No.	PGMA / Description	Surface Preparation & Surface Profile	Primer coat		Intermediate Coat		Finish coat			Total DFT μm (min)
			Paint	No. of coats	Paint	No. of coats	Paint	No. of coats	Shade	
4 PS3 (Contd.)	Hot Air: 48-018,202,204,207,208,212,214; 48-222,224,232,234,262,264,662,664,667; Flue Gas: 48-372,382,384,386, 432,434; 48-462,464,482, 484 ,492,494;	SSPC-SP3/ Power Tool Cleaning	Red Oxide Zinc phosphate Primer (Alkyd Base) to IS 12744 DFT= 30 μm per coat	2	--	--	--	--	Red oxide	60
5 PS 9B1	<u>Components >95° C uninsulated other than components coming in gas path.</u> Temp: >95° C & <400° C 20-511; 24-807,820,860,865,867; 42-200,300,358; Instrument tappings, doors 48-200,915;	Blast cleaning to SA2 ½ (Near white metal) with surface profile 35-50 μm	Inorganic Ethyl Zinc Silicate Primer DFT=75 μm per coat	1	--	--	Heat Resistant Aluminium Paint to IS 13183 Gr.II DFT=20 μm per coat	2	Aluminium	115
6 PS 10	<u>Components uninsulated other than components coming in gas path.</u> Temp: >400° C & <600° C 09-003,004,005,503; 28-220;	SSPC-SP3/ Power Tool Cleaning	Heat Resistant Aluminium Paint to IS 13183 Gr. I DFT=20 μm per coat	1	--	--	Heat Resistant Aluminium Paint to IS 13183 Gr. I 20 μm per coat	1	Aluminium	40
7 PS2	<u>Loose tubes, SH, RH & Eco. coils</u> 11-074,078,095,374,378,406,416,467,469; 11-487,491,494,606,684,694,716,718; 11-767,769,787,791,967; 11-969,991;12-179,184,187,368,395,403,405,495; 12-514,524,544, 548,554,568; 12-800,803,805,903,914,917,924,927,928,944,948; 12-954,968; 16-079,201,202,203,270,379; 19-814,824,853,914,924;	SSPC – SP2 or SSPC – SP3 Hand tool / Power tool cleaning	Red Oxide Zinc Phosphate Dip coat primer to PR: CHEM: 09 – 03 DFT=35 μm per coat	1*	--	--	--	--	Red Oxide	35

*-Wherever dip painting is not possible, 2 coats of brush painting of Red oxide Zinc Phosphate primer to a coating thickness of 60 μ is also permitted in line with Sr.No.9.

Sl. No.	PGMA / Description	Surface Preparation & Surface Profile	Primer coat		Intermediate Coat		Finish coat			Total DFT μm (min)
			Paint	No. of coats	Paint	No. of coats	Paint	No. of coats	Shade	
8 PS1A	<p>Components < 95° C –Other than components in Sl.No.3.</p> <p>Miscellaneous and casing sheets</p> <p>07-409,431,460,461,462,502,503,531,560,561; 12-906,907; 17-919; 21-601,604,606; 24-350,351,354,800,801,804,805,806,808,809; 24-810,815,817,825,826,835,840,841,855; 24-950,955,960;30-233,234;35-995; 36-611,621; 39-302; 04-147;</p> <p>Fuel firing: 41-350,390,500;</p> <p>Steam blowing piping 42-001,002,005,010,046,065,070,120,152,154; 42-157; 43-004,104,105,200; 45-200,801,802,804,805,858; 47- 261,263,858;</p> <p>Duct plates, expansion joints 48-911,912;</p> <p>Coal Feeding 65-736; 67-204,272,276,283,801,802,803; 95-088,089,091,485;96-186;97-585,591,592;</p> <p>Impulse lines: 24-800; Seal air ducting: 43-005, 105; Cold Air duct:48-012,014,112,114,141; Tempering Air: 48-142,144;</p>	SSPC-SP3/ Power Tool Cleaning	Red Oxide Zinc Phosphate Primer (Alkyd Base) to IS 12744 DFT= 30 μm per coat	1	--	--	Synthetic Enamel paint (Long Oil Alkyd) to IS 2932 DFT= 20 μm per coat	2	Smoke Grey Shade No: 692 of IS5	70

Sl. No.	PGMA / Description	Surface Preparation & Surface Profile	Primer coat		Intermediate coat		Finish coat			Total DFT μm (min)
			Paint	No. of coats	Paint	No. of coats	Paint	No. of coats	Shade	
9 PS3	<u>Components >95° C coming in the gas path, Headers, Commissioning Spares & erection Materials etc.,</u> 05-137,147;06-400,401,431,434,437,441,444; 06-447,451,453,455,500,501,731,732; 06-734,735,737,741,744,745,747,751,752,753; 06-755, 759; 07-309,315,316,318,423,993; 10-182,183,184,185; 11-474; 12-993;17-174,474,504,506,900,903; 19-704,753,763,783,793,802,850,851; 20-988,998; 21-987; 24-822,823, 987,989, 993; 30-105,211,215,219,223,224,235; 31-010,104; 32-010,210,810; 37-010;42-858;48-993; 65-200; 67-200;96-193; 97-282,590; 99-501; 41-988; 42-988;	SSPC-SP3/ Power Tool Cleaning	Red Oxide Zinc Phosphate Primer (Alkyd Base) to IS 12744 DFT= 30 μm per coat	2	--	--	--	--	Red oxide	60
10 PS6	<u>Hand rails and posts, ladders / rungs</u> 34-810,820,850; 35-821,822,823,851; 36-820,851,852,853; 38-820,850;39-820,850; <u>Floor Grills, Step treads</u> 35 – 811,812;36-811,812,813,814; 38 – 810;39 – 810;	Acid pickling to SSPC-SP8	Hot dip Galvanizing to a coating weight of 610 g/m ² (minimum) and to a coating thickness of 85.0 microns (minimum). Refer Notes given below **							

Notes **: The Guard plates, Hood Ladders and Stringer channels shall be painted as per painting scheme prescribed in Sl. No: 03

PAINTING SCHEME FOR VALVES

Sl.No.	PGMA / Description	Surface Preparation & Surface Profile	Primer coat		Intermediate coat		Finish coat			Total DFT μ m (min)
			Paint	No. of coats	Paint	No. of coats	Paint	No. of coats	Shade	
11 PS 10	<u>Cast carbon steel valves (Conventional)</u> <u>Cast alloy steel valves (Conventional)</u> <u>All API valves, QCNRV, SV & SRV Silencers,</u> 21-800,825, 24-885; Safety valves & ERV 21-850; 24-880,881;	SSPC-SP3/ Power Tool Cleaning	Heat Resistant Aluminium Paint to IS 13183 Gr. I	1	--	--	Heat Resistant Aluminium Paint to IS 13183 Gr. I	1	Aluminum	40
	Forged valves	Chemical cleaning	Phosphating to a coating weight of 1500 mg per Sq.ft.	--	--	--	--	--	--	--
1AS1	<u>Soot Blower components</u> 20-051,054,201,204,794,962;	SSPC-SP3/ Power Tool Cleaning	HB Chlorinated Rubber based Zinc Phosphate Primer DFT= 50 μ m per coat	1	--	--	Syn. Enamel paint (Long Oil Alkyd) to IS 2932 DFT= 20 μ m per coat	2	Verdigris Green Shade No. 280 of IS5	90
	HP / LP system	SSPC-SP3/ Power Tool Cleaning	Heat Resistant Aluminium Paint to IS 13183 Gr.I	2	--	--	--	--	--	40

Sl.No.	PGMA / Description	Surface Preparation & Surface Profile	Primer coat		Intermediate coat		Finish coat			Total DFT μm (min)
			Paint	No. of coats	Paint	No. of coats	Paint	No. of coats	Shade	
12 PS15	<u>For CLH & VLH*</u> PGs 07,08,12,17,19,21,24,47,48 &80 07-402,403,405,505;12-517,528; 17-519,904,906 19-506,507,904,905, 906,907; 24-353; 48-206,395;	Blast cleaning to SA2 ½ (Near white metal) with surface profile 35-50 μm	Epoxy zinc rich primer To IS 14589 Gr. II % VS=35, (min) DFT=40 microns per coat	1	--	--	Aliphatic acrylic Poly-urethane paint % VS=40.0 (min) DFT=30.0 microns per coat	1	Phirozi Blue Shade No. 176 of IS5	70
13 PS33A	<u>Components > 95°C, un-insulated Fuel pipes</u> 47-269;	Blast cleaning to SA2 ½ (Near white metal) with surface profile 35-50 μm	Inorganic Ethyl Zinc Silicate Primer DFT=75 μm per coat	1	Heat Resistant Aluminium Paint to IS 13183 Gr.II DFT=25 μm per coat	2	Heat Resistant Aluminium Paint to IS 13183 Gr.II DFT=20 μm per coat	1	Aluminum	145
14 PS 5B	All Columns below '0' level (embedded in concrete) PGs 34,35,36,38 39	SSPC-SP3/ Power Tool Cleaning	Rust Preventive Fluid to PR: CHEM: 09 – 04 DFT=20 μm per coat	2	--	--	--	--	--	40

*- For components other than CLH & VLH, painting scheme shall be as given in Sl. No. 8.

NOTES:

1. Rust Preventive Coating should be given on HSEFG Bolt and nut threads.
2. Machined surfaces and all retainers are to be applied with a coating of Temporary Rust Preventive oil.
3. All threaded and other surfaces of foundation bolts and its materials, insulation pins, Anchor channels, Sleeves, shall be coated with Temporary Rust Preventive Fluid and during execution of civil works; the dried film of coating shall be removed using organic solvents.
4. Ground shade/ Colour of Finish paints & identification tag/Band for equipments, pipings pipe service, boiler supporting structures and other boiler components shall be followed as per doc. No. Vol-II Section 2-25 Painting_R0.
5. PGMA's under Sub-Vendor items are not indicated. For all bought-out and sub-vendors items including PGMA's mentioned above falling under the scope of BHEL the same scheme as for main equipment as covered in this document shall be followed.
6. This painting Schemes is valid for only Customer No: U6/1729 & 1730, TANGEDCO UDANGUDI STPP - 2X660 MW.
7. No painting is required for Stainless Steel, non-ferrous & galvanized components.
8. Wherever inside surfaces of components under PGMA 48 – XXX & others, need protection till erection, two coats of Red-oxide zinc phosphate primer paint to IS12744 to a DFT of 60 microns shall be applied, after power tool cleaning.
9. The Temporary Rust Preventive coating that already been applied on any components, tubes, pipes etc., shall be visually inspected for good adherence. If the coating is intact, direct coating of alkyd based red oxide paints over the coating is permitted. In case, the coating has peeled off over a large area, then the coating is to be removed by suitable solvents / heating to 350 –400 °C for an hour before primer paint application –but, in this case, it should be ensured that the minimum surface cleanliness required for primer paint application shall be SSPC – SP2 (equivalent – Hand Tool cleaning).
10. In components, wherever plates / sheets of thickness less than or equal to 5 mm and rods of <25mm/tubes/drain pipes are used, power tool / hand tool cleaning to SSPC – SP3 / SP2 shall be followed and the painting shall be done as described in Sl.No.8.
11. For all commissioning components-erection materials (xx-993) two coats of Red oxide Zinc Phosphate Primer shall be applied to meet the temporary protection till erection, after power tool cleaning.
12. Touch-up paintings, making good any damaged shop painting and completing any unfinished portion of the shop coat shall be carried out as per clause applicable painting scheme.
13. All components covered under different PGMA's are to be painted. In case any component is left out, the same shall be deemed to be included under the relevant section based on paint logic approved.
14. For very small components like clamps etc. Sl.No.8 shall be followed.

15. For very small components with weldable primer at edges, the entire component shall be applied with weldable primer. Structural members having welded connections at site, relevant area can be painted with primer paint instead of Weldable primer.
16. Painting scheme for all temporary structures like 04-196, 35-391,392,393 shall be PS 1AE i.e. 1 coat of Red oxide Zinc Phosphate primer (Alkyd Base) to IS 12744-DFT-30 μ and 2 coats of Synthetic Enamel paint (Long Oil Alkyd) to IS 2932-DFT-2X20 μ Shade Yellow –Shade No. 356 of IS 5- Total DFT 70 μ . These are to be cut & removed at site after erection. (It excludes components covered under Sr. No. 3 & 10 of description table).
17. For internal protection of Pipes, tubes, headers and other pressure parts, Volatile Corrosion Inhibitor (VCI) pellets shall be put (after sponge testing/ draining/ or drying) and subsequently end capped. The dosage of VCI pellets shall be approximately 100 g/ Cu.m. For tubes typically 4 – 5 tablets per end are to be put. For C & I items the dosage of self-indicating Silica Gel (colourless) shall be 250 g/ cu.m. (About 2 to 3 bags weighing approximately 100 grams each). VCI pellets shall not be used for stainless steel components and its composite associates.
18. All threaded components of spring assemblies and turnbuckles shall be galvanized and achromatized to 15 microns minimum thickness.
19. Soot blower components i.e Valve head assembly having high surface temperature (> 200 and <600 deg. C) shall be applied with protective coating as per PS9 (up to 400 deg.C) and PS10 (up to 600 deg.C)
20. Corner plate, sheet channel and fixing pins of PGMA 32-210 shall be painted as per scheme PS3 to total DFT of 60 microns.
21. It is mandatory that for finish coat each layer shall have a permanent DFT and free from any paint defects like sags, wrinkles etc. Total DFT of a component correspond to respective painting scheme has to be ensured and recorded by inspection agency as per QP.
22. For chequered plates having thickness ≤ 5 mm, surface preparation can be power tool cleaning to St3 and painting shall be in line with Sl. No. 8.
23. Handrails, step treads of PGMA under Sl. No. 3 need to be galvanized in line with scheme for handrails (i.e. Sl. No. 10).
24. Inside surfaces of fabricated structure (e.g. Box type column) shall be painted with two coats of red oxide primer paint during fit up stage.
25. Painting of bunker structures to be in line with painting scheme of supporting structures (Sl. No. 3).
26. Faying surfaces of bolted connection (Friction Grip, Slip- Critical) shall be masked to prevent application of coating. Joints to be site welded shall have no paint applied within 100 mm of welding zone. Similarly, where Friction grip fasteners are to be used no painting shall be provided. On completion of the joint, the surfaces shall receive the paint as specified.

Painting Scheme – Details for procurement & application purposes

Sl. No.	Generic nature of paint	Theoretical Covering Capacity Sq.m per Litre.	No. of pack	Volume solids, % (min)**	DFT in microns per coat (approx.)	Shade	Shade No. to IS5	Mode of appln.	Over coating interval, Hrs.
1	Epoxy Zinc rich primer to IS14589 Gr.II (latest)	8	2	35	40	Grey	--	Spray	24
2	Aliphatic acrylic polyurethane paint to IS 13213 (latest)	13	2	40	30-50	Phirozi – Blue/ Dark admiralty grey	176/632	Spray	24
3	Heat resistant Aluminium paint to IS 13183 Grade I/II (latest)	10	1	-	20	--	--	Brush / Spray	24
4	Red oxide zinc phosphate primer paint to IS 12744 (latest)	10	1	--	30	-	--	Brush / Spray	12
5	Red oxide Zinc Phosphate Dip coat primer paint to PR: CHEM: 09-03	10	1	--	35	--	---	Dip	12
6	Long oil alkyd synthetic enamel finish paint to IS2932 (latest)	17	1	--	20	Reqd. shade	Corrpdg. Shade no.	Brush / Spray	12
7	Temporary Rust preventive fluid to PR: CHE: 09 – 04	10	1	--	25	--	--	--	12
8	General purpose Aluminium paint to IS 2339 (latest)	10	2	--	20	Aluminum	--	Brush	12
9	HB Chlorinated Rubber Based Zinc Phosphate Primer-Colour Grey	8	1	40	50	Grey	--	Brush / Spray	12
10	Epoxy based polyamide cured MIO pigmented intermediate coat.	8	2	60	100	Brown	--	Spray	24
11	Inorganic ethyl zinc silicate primer to IS 14946 (%Zn on dry film= 75min)	8	2	60	75	Grey	--	Spray only	16

Brush painting is accepted, if recommended by the paint suppliers. The covering capacity of paints specified is only approximate. The paints and Rust Preventive fluid shall be procured from BHEL's approved suppliers. **Values are indicative.

Painting of Damaged Areas

(Areas where the paint has deteriorated badly by erosion and areas where the paint film has lost its adhesion and where the steel has rusted appreciably, should be repainted as follows)

Sl.No.	Components	Surface Preparation	Primer coat		Intermediate coat		Finish coat			Total DFT μm (min)
			Paint	No. of coats	Paint	No. of coats	Paint	No. of coats	Shade	
1	Paint damaged components fall under Sl.no: 3	Power tool cleaning to bare metal	Epoxy zinc rich primer to IS 14589 Grade II	2 Total DFT 75 μ (min)	As given in scheme	2	As given in scheme	1	As given in scheme	325
2	Paint damaged components fall under Sl.no: 1,2,4,5,6,7,8,9,11,12,13.	Power tool cleaning to bare metal	As given in scheme	As given in scheme	As given in scheme	As given in scheme	As given in scheme	As given in scheme	As given in scheme	As given in scheme

Technical Pre-Qualification Criteria (PQR)

Technical Pre-Qualification Requirement for HEA Igniters

1. The vendor shall be an established retractable HEA (High Energy Arc) igniter (henceforth referred as Igniter) manufacturer and having adequate Engineering, Manufacturing, testing and servicing facilities. Vendor to Submit back-up documents for the same.
2. The supplier shall have experience of having supplied Igniters for igniting No.6 oil in thermal power plants or for the application of similar severity and to meet the technical parameters of exciter, spark rod, spark tip and retractor as per technical specification of enquiry or higher.
3. The igniter and its accessories offered shall be from the existing regular supply range of the supplier.
4. As proof of above pre-qualifying requirement points, vendor should submit :
 - a. Their manufacturing product catalogue which lists the enquired igniter as per above technical requirements.
 - b. Vendor shall furnish general reference list with details of Customer name, Oil handled, igniter parameter, P.O date, and customer reference details wherein the vendor has supplied igniters meeting the technical requirements as stated in this enquiry or higher.
 - c. Minimum ONE end user certificate for the satisfactory operational performance of their supplied igniter, meeting the minimum pre- qualifying requirements stated above.

OR

Minimum two purchase order meeting the minimum pre- qualifying requirements stated above.

- d. Vendor to attach the corresponding data sheets/ technical documents of the igniter supplied as per P.O / End user certificate (submitted vide point 4.c) for our review.
5. In case of order placement, the Vendor shall have the responsibility for the followings and same to be confirmed point wise.
 - a) Vendor should have the component replacement responsibility in case of defect / failure.
 - b) Vendor shall provide assistance in commissioning activities at site, if required.
 - c) Vendor should ensure that their product would perform as intended during erection & commissioning.
6. Backup document checklist to meet PQR to the fullest satisfaction of BHEL:

S. No	Document description	Check list
a.	Back-up documents as per pt. 1	<input type="checkbox"/>
b.	Product Catalogues as per pt. 4a	<input type="checkbox"/>
c.	General reference list as per pt. 4b	<input type="checkbox"/>
d.	One end user certificate OR Two P.O as per pt. 4c	<input type="checkbox"/>
e.	Data sheets/ technical documents as per pt. 4d	<input type="checkbox"/>
f.	Confirmation to clause (5)	<input type="checkbox"/>



BHARAT HEAVY ELECTRICALS LIMITED
TIRUCHIRAPPALLI - 620 014, INDIA.
QUALITY ASSURANCE DEPARTMENT

STANDARD QUALITY PLAN FOR HEA IGNITORS

SQP:SD:26 Rev No: 00

Page: 1 of 4

Prepared By
Quality Assurance

VENKANNA RUPANI

R. Venkanna
11/12/2018

Reviewed by	Signature
Quality Assurance (G. PANNEER SELVAM)	 11/12/18
Engineering / FB (G. SARAVANA KUMAR)	 11.12.2018
Materials Management / BOI (M. SOMASUNDARAM)	M. Som 11.12.18
Quality Control (R. DHARMAR)	 11/12/18

Rev No	Date	Approved by	Signature
00	11/12/2018	AGM / QA & BE	 11/12/18

Record of Revisions

Rev No	Details of Revision	Remarks
00	Fresh Issue	

Proprietary Data - For Internal Use Only

	MANUFACTURER'S NAME & ADDRESS: BHEL: TIRUCHIRAPPALLI APPROVED SUPPLIERS		STANDARD QUALITY PLAN					QWI NO: SQP:SD:26 REV NO: 00 DATE: 11/12/2018 PAGE: 2 OF 4						
			PRODUCT: HEA IGNITORS											
			SUB-SYSTEM : Steam Generator and Auxiliaries											
SL. NO	COMPONENT & OPERATIONS	CHARACTERISTICS	CLASS	TYPE OF CHECK	QUANTUM OF CHECK		REFERENCE DOCUMENT	ACCEPTANCE NORMS	FORMAT OF RECORD	AGENCY			REMARKS	
1	2	3	4	5	M	C/N	7	8	9	D*	M	C	N	11

1.0 RAW MATERIALS														
1.1	SS Pipes, Rods, Pipe Fittings (Critical Material)	Chemical & Mechanical Properties; Dimensions	Major	Review of Documents	100%	100%	BHEL Approved Drawings / Data Sheet	BHEL Spec. & BHEL Approved Drawings/ Data Sheet	MTC/ALC	√	P	V	-	
2.0 INPROCESS CONTROL (Fabrication & Assembly)														
2.1	Welding Qualifications	Procedure	Major	Documents Review	100%	100%	AWS D1.1/1.6/ ASME Sec IX		PQR & WPS	√	P	V	V	
		Personnel	Major	Documents Review	100%	100%	AWS D1.1/ 1.6 / IBR / ASME Sec IX		WPQ	√	P	V	V	
2.2	Machining Components	Surface & Dimensional	Minor	Visual & Measurement	100%	--	Supplier Drawings	Supplier Drawings	COC	-	P	-	-	
2.3	Cleaning & Finishing	Visual	Minor	Surface Finish	100%	--			COC	-	P	-	-	-
2.4	NDE On Welds	Weld Soundness	Major	MPI/LPI	100%	10%	AWS D 1.1/1.6 or ASME Sec V	AWS D1.1/1.6 or ASME Sec VIII Div 1 Appd 6/8	IR	√	P	V	-	
3.0 OTHER ITEMS:														
3.1	Limit Switches	Visual Verification of Components & Switch Actuation	Major	Operational/ Performance Test	100%	100%	BHEL Approved Drawings / Data Sheet	BHEL Spec. & BHEL Approved Drawings/ Data Sheet	IR/ TC	√	P	V	-	
3.2	Solenoid Valve	End/Port Connection & Voltage Rating	Major	Review of Documents	100%	100%			IR/ TC	√	P	V	-	
3.3	Power Cylinder	Functional Check, Mountings & Accessories	Major	Review of Documents	100%	100%			IR/ TC	√	P	V	-	
3.4	Power Pack	Power on Test	Critical	Visual	100%	100%			IR/ TC	√	P	V	-	
3.5	Power Cable	Visual, Test Certificates	Major	Visual & Review of Documents	100%	100%			IR/ TC	√	P	V	-	
3.6	Ignitor Spark Tip	Dimensional & Threads, Sparking	Major	Visual & Review of Documents	100%	100%			IR/ TC	√	P	V	-	

LEGEND: * RECORDS IDENTIFIED WITH "TICK" (√) SHALL BE ESSENTIALLY INCLUDED BY THE SUPPLIER IN QA DOCUMENTATION;
**** M:** MANUFACTURER, **C:** BHEL QC/BHEL AIA, **N:** CUSTOMER, **P:** PERFORM, **W:** WITNESS, **V:** VERIFICATION; **CLASS:** A - CRITICAL; B - MAJOR; C - MINOR;
MTC- Manufacturer's Test Certificate; IR- Inspection/Test Report; COC: Certificate of Compliance; (R): Routine test; (I)/(Ts): Type test.

	MANUFACTURER'S NAME & ADDRESS: BHEL: TIRUCHIRAPPALLI APPROVED SUPPLIERS	STANDARD QUALITY PLAN						QWI NO: SQP:SD:26					
		PRODUCT: HEA IGNITORS						REV NO: 00 DATE: 11/12/2018					
		SUB-SYSTEM : Steam Generator and Auxiliaries						PAGE: 3 OF 4					
SL. NO	COMPONENT & OPERATIONS	CHARACTERISTICS	CLASS	TYPE OF CHECK	QUANTUM OF CHECK		REFERENCE DOCUMENT	ACCEPTANCE NORMS	FORMAT OF RECORD	AGENCY			REMARKS
					M	C/N				M	C	N	
1	2	3	4	5	M	C/N	7	8	9	D*	**	10	11

3.7	Exciter	Functional check	Major	Visual	100%	10%	BHEL Approved Drawings / Data Sheet	BHEL Spec. & BHEL Approved Drawings/ Data Sheet	IR	√	P	V		
I)	Spark Count Energy Level Verification	Functional check	Major	Measured	100%	10%			IR	√	P	V	-	
II)	Burn In & Elevated Temp. Test	Functional check	Major	Visual	1 per Lot	1 per Lot			IR/TC	√	P	V	-	
3.8	Flexible Cable Assy.	Dimensions & Make	Major	Measurement & Review of Documents	100%	10%	BHEL Approved Drawings / Data Sheet	BHEL Spec. & BHEL Approved Drawings/ Data Sheet	IR	√	P	W	-	
3.9	Flexible Spark Rod	Size, Location & Connection	Major	Measurement	100%	10%			IR	√	P	V	-	
3.10	Retractor Assembly includes HEA Flexible/Rigid Spark Rod, Flexible Cable	Advance/ Retract Movement Check; Dimensional & Functional	Critical	Visual Dimension & Input Supply	100%	10%	BHEL Approved Drawings / Data Sheet	BHEL Spec. & BHEL Approved Drawings/ Data Sheet	IR	√	P	W	V	
4.0	FINAL ASSEMBLY & ROUTINE TESTS (R)													
4.1	HEA Ignitor Assy.	Dimension Verification, Visual Fitment, matching & BOM, Spark Test (No. of Spark/Min) Electrical Rating for Ignitor at operating voltage	Critical	Measurement, Visual, Physical Match	100%	10%	BHEL Approved Drawings / Data Sheet	BHEL Spec. & BHEL Approved Drawings/ Data Sheet	IR	√	P	W	V	
4.2	a) Function Test -Insulation resistance test before and after HV Test	Function check of HV Cable and spark Rod for 5MΩ	Major	Electrical, Visual & Operational Test	100%	10%	BHEL Approved Drawings / Data Sheet	BHEL Spec. & BHEL Approved Drawings/ Data Sheet	IR/TC	√	P	W	V	
4.2	b) -High Voltage / Dielectric Test at 7500 V DC for 50 sec - Electrical Rating Check for ignitor at operating Voltage	Function check	Major	Visual & Operational Test	100%	10%	BHEL Approved Drawings / Data Sheet	BHEL Spec. & BHEL Approved Drawings/ Data Sheet / No breakdown	IR/TC	√	P	W	V	OEM Certificate for HV/IR test shall be submitted during inspection.

LEGEND: * RECORDS IDENTIFIED WITH "TICK" (√) SHALL BE ESSENTIALLY INCLUDED BY THE SUPPLIER IN QA DOCUMENTATION;
**** M:** MANUFACTURER, **C:** BHEL QC/BHEL AIA, **N:** CUSTOMER; **P:** PERFORM. **W:** WITNESS, **V:** VERIFICATION; **CLASS:** A - CRITICAL; B - MAJOR; C - MINOR;
MTC- Manufacturer's Test Certificate; IR- Inspection/Test Report; COC: Certificate of Compliance; (R): Routine test; (I)/(Ts): Type test.

	MANUFACTURER'S NAME & ADDRESS: BHEL: TIRUCHIRAPPALLI APPROVED SUPPLIERS	STANDARD QUALITY PLAN							QWI NO: SQP:SD:26				
		PRODUCT: HEA IGNITORS							REV NO: 00 DATE: 11/12/2018				
		SUB-SYSTEM : Steam Generator and Auxiliaries							PAGE: 4 OF 4				
SL. NO	COMPONENT & OPERATIONS	CHARACTERISTICS	CLASS	TYPE OF CHECK	QUANTUM OF CHECK		REFERENCE DOCUMENT	ACCEPTANCE NORMS	FORMAT OF RECORD	AGENCY			REMARKS
					M	C/N				M	C	N	
1	2	3	4	5	M	C/N	7	8	9	D*	**	10	11

c)	HEA Ignitor Testing Kit, if applicable	Function check	Major	Visual & Operational Test	100%	10%	BHEL Approved Drawings / Data Sheet	BHEL Spec. & BHEL Approved Drawings/ Data Sheet	IR/ TC	√	P	W	V	
5.0	TYPE TESTS (Ts)													
5.1	Enclosure Test for Exciter and Junction Box	Type Test	Major	Review of Documents	One Per Type	One Per Type	NEMA Standard	BHEL Spec. & BHEL Approved Drawings/ Data Sheet	IR	√	V	V	V	
5.2	Dry Heat Damp Recycling Test for exciter components	Type Test	Critical	Review of Documents	One Per Type	One Per Type	IEC 60068-2-30	IEC 60068-2-30 / BHEL Approved Drawing/ Data Sheet	IR	√	V	V	V	Type Test Valid for 5 years.
5.3	Tip Life at 650 Deg. C Test Furnace	Type Test	Critical	Review of Documents	One Per Type	One Per Type	Manufacturer's Standard	300 kW/ BHEL Approved drawing/data sheet	IR	√	P	V	V	
5.4	Spark Rate at specified Voltage	Electrical (Spark Rate, Output Voltage)	Critical	Review of Documents	One Per Type	One Per Type	Manufacturer's Standard	± 10% / BHEL Approved Drawing/ datasheet (whichever is stringent)	IR	√	P	W	V	
5.5	First Loop Power*	Type Test	Critical	Review of Documents	One Per Type	One Per Type	Manufacturer's Standard	10 ⁶ sparks/ BHEL approved drawing/ datasheet	IR	√	V	V	V	
*Measurement graph of voltage & current from OEM shall be submitted from which first loop power shall be calculated.														

Notes:

- Customer stages specified above, under column "N", shall be followed. Additional Customer witness/verification stages, if required, shall be as specified in BHEL PO.
- The latest editions/ revisions of the above mentioned /referred standards / procedures /specifications shall be used.

LEGEND: * RECORDS IDENTIFIED WITH "TICK" (√) SHALL BE ESSENTIALLY INCLUDED BY THE SUPPLIER IN QA DOCUMENTATION;
**** M:** MANUFACTURER, **C:** BHEL QC/BHEL AIA, **N:** CUSTOMER, **P:** PERFORM. **W:** WITNESS, **V:** VERIFICATION; **CLASS:** A - CRITICAL; B - MAJOR; C - MINOR;
MTC- Manufacturer's Test Certificate; IR- Inspection/Test Report; COC: Certificate of Compliance; (R): Routine test; (T)/(Ts): Type test.



**FUEL SYSTEM
PE (BOILERS)**

TOS: 1930 / REV : 02
Page | 1 of 10

SPECIFICATION FOR HEA IGNITORS

1. The specification Contains :
Part I – Specification for HEA Ignitor
Part II A – Contract specific requirement of HEA Ignitor Assembly.
Part II B – Data sheet confirmation by Vendor.
2. If the requirement of part II A is differing with part I. The requirement of part II A will be mandatory.
Vendor should fill up the Part II after studying Part I and submit along with offer.
3. Vendor should fill up the Part II datasheet if any after placement of order and submit for approval.
4. Vendor offer is liable to be rejected if part II is not filled up and submitted with offer or incomplete submission.

PREPARED BY:
P.DURAISAMY

CHECKED BY:
M.ANBAZAGAN

APPROVED BY :
M.THANDAPANI

DATE:
23.03.2008

REV No.	DETAILS	REVISED BY	APPROVED BY	DATE
REV-01	General spec. revision	-Sd-	-Sd-	24.03.2015
REV-02	Specification as such revised based on MOU exercise.	N. Fazil	M. Thandapani	30.03.2017



PART-1 - SPECIFICATION FOR HEA IGNITOR

1.0 Description:

Retractable HEA Ignitor complete with Pneumatic Retractor, Exciter, Flexible cable, Spark rod and Spark Tip.

2.0 Application:

To ignite No.2 through No.6 fuel oils in a corner fired boilers or wall fired boilers.

3.0 Ignitor Type:

High Energy Arc capacitive discharge type or Thyristor type.

3.1.0: Excitor: Option: 1

- | | | |
|---------|----------------------|--|
| 3.1.1.0 | Input Voltage | : 110V AC + 10%,-15%, 50 ± 5 Hz
240V AC + 10%,-15%, 50 ± 5 Hz
(Refer clause 8.2 for contract specific requirements). |
| 3.1.1 | Output voltage | : 2000 V DC |
| 3.1.2 | Stored energy | : 12 Joules/Spark. * |
| 3.1.3 | Spark rate | : 4 per second minimum at rated voltage & frequency. * |
| 3.1.4 | Spark discharge time | : Total discharge time of 30 micro second; 6.3 micro second for first loop, when connected with 4 m long flexible cable. |
| 3.1.5 | First loop power | : 525 KW (Measured at tip) |
| 3.1.6 | Duty cycle | : 15 min. On, 30 min. OFF |
| 3.1.7 | Enclosure | : NEMA 4, Weather proof, openable type |
| 3.1.8 | Working temp (Min.) | : 75 deg C. |
| 3.1.9 | Working temp (Max.) | : 110 deg C. |

3.1.0: Excitor: Option: 2

- | | | |
|---------|----------------------|--|
| 3.1.1.0 | Input Voltage | : 110V AC + 10%,-15%, 50 ± 5 Hz
240V AC + 10%,-15%, 50 ± 5 Hz
(Refer clause 8.2 for contract specific requirements). |
| 3.1.1 | Output voltage | : 1500 V DC |
| 3.1.2 | Stored energy | : 4.5 Joules/Spark. * |
| 3.1.3 | Spark rate | : 20 Sparks per second minimum at rated voltage & frequency. * |
| 3.1.4 | Spark discharge time | : Total discharge time of 30 micro second; 6.3 micro second for first loop, when connected with 4 m long flexible cable. |
| 3.1.5 | First loop power | : 500 KW (Measured at tip) |



- 3.1.6 Duty cycle : 300 Sec at ED50%. Initial switch phase 60 sec @ 20 sparks / sec.
- 3.1.7 Enclosure : NEMA 4, Weather proof, openable type.
- 3.1.8 Working temp (Min.) : 75 deg C.
- 3.1.9 Working temp (Max.) : 110 deg C.
- (* Min. energy shall be maintained)
- 3.2.0 Spark Rod** : Flexible / Rigid
(Refer clause 8.4 for contract specific requirements).
- 3.2.1 Total length : As required \pm 3 mm.
(Refer clause 8.5 for contract specific requirements).
- 3.2.2 Flexible portion, if required : 900mm long, designed for 100 mm min., radius of bend flexing duty.
- 3.2.3 Maximum outer dia : 15.9 mm max. at any section.
- 3.2.4 Wire : Suitable for 540 deg. C maximum temperature and voltage of 2500 V DC, water and oil resistant insulation & should withstand flexing duty.
- 3.2.5 End connectors : Non - rotating type; material should ensure no binding during working.
- 3.2.6 Firing end rigid portion : Max. 235mm (when measured after tip is mounted).
- 3.2.7 Ambient temp : 110 deg. at cable end, 540 deg C at tip end.
- 3.3.0 Spark Tip:**
- 3.3.1 Max. Working temp : 650 deg C at tip (inserted approx.15 seconds into the furnace for every light up).
- 3.3.2 Tip life : 10^6 Sparks (or) 10000 burner starts of 15-20 sec. / each start.
- 3.3.3 Construction : With end seal to avoid oil soaking into the spark tip.
- 3.4.0 Flexible Cable** : To connect excitor and spark rod.
- 3.4.1 Length : 3658 ± 50 mm.
- 3.4.2 Construction : High temp. Cable with metal braided armored SS conduit with PVC outer protection.
- 3.4.3 Ambient temp : Max. 110 deg C.
- 3.5.0 Retractor:**
- 3.5.1 Air cylinder : 1 NO. Heavy duty cylinder 38 - 40 mm dia
- 3.5.1.1 Air cylinder stroke : 5" (127mm) / 8" (203mm) / 12" (305 mm)
(Refer clause 8.1 for contract specific requirements).
- 3.5.2 Air pressure : 3 to 7 kg/cm² (g), dry air.



- 3.5.3 Solenoid valve : 1 No., single coil, 4-way, class H coil; energize to advance Spark rod; de energize to retract spark rod; suitable for any one of the following voltage, as per specification.
: 110V AC + 10%,-15%, 50 Hz \pm 5 Hz /
: 240V AC + 10%,-15%, 50 Hz \pm 5 Hz /
: 24V DC
(Refer clause 8.2 for contract specific requirements).
- 3.5.3.1 Enclosure : NEMA 4
- 3.5.4 Limit switches : 2 Nos. with DPDT / Two Circuit double break contacts;
240 VAC, 10 Amps. Rating.
- 3.5.5 Clamp Assembly : Should be firm and designed such that clamping / de clamping does not disturb Limit Switch actuating clamp position and clamp does not slip in operation.
- 3.5.6 Working temp (Min) : 85 deg C.
- 3.5.7 Junction box : All wiring from solenoid valve and limit switches shall be terminated in a junction box.
: The junction box shall be of water and dust proof NEMA 4 construction with 22.2mm hole for 1/2" conduit entry.
Heat resistant wires of 20 SWG min shall be used.

4.0 INSPECTION & TESTS:

- 4.1 Following type test certificates shall be furnished:
- Enclosure Certification for exciter box & Junction box.
 - Dry heat damp recycling test as per IEC: 68-2-30 for exciter components.
 - Tip life, in 650 Deg C test furnace.
 - Spark rate at specified voltage.
 - First loop power.

- 4.2 Following works test certificates shall be furnished:

- Insulation test for exciter flexible cable and spark rod minimum 5 M Ω .
- Dielectric test for 7500 V DC for 50 seconds.
- Certificates for satisfactory working of exciter and retractor.

5.0 DOCUMENTS:

Following documents are required:

- 5.1 1 set of offer documents with point by point confirmation / deviation without which offer will be rejected.



**FUEL SYSTEM
PE (BOILERS)**

TOS: 1930 / REV : 02

Page | 5 of 10

- 5.2 1 Set of constructional drawings with offer.
- 5.3 1 Set of Test Certificates.
- 5.4 1 set of O&M and troubleshooting manual with detailed spares identification drawings along with soft copy.

6.0 GUARANTEE:

For 12 months from the date of commissioning or 18 months from the date of supply whichever is earlier.

7.0 PACKING

Each item shall be separately packed in sea worthy casings with purchasers and supplier's part numbers/ material code numbers. The damaged items due to inadequate packing shall be replaced free of cost.



Part II A – Contract specific requirement of HEA Ignitor Assembly.

8.0 Contract Specific Requirements for HEA Ignitor Assembly:

Project Name: TANGEDCO UDANGUDI 2X660MW

Customer No: 1729 & 1730

- 8.1: HEA Retractor Assy Stroke Length (12") 127 MM (5") 203 MM (8") 305 MM
- 8.2: Solenoid Valve voltage for HEA Retractor Assy 110V AC + 10%,-15%, 50 Hz \pm 5 Hz
 240V AC + 10%,-15%, 50 Hz \pm 5 Hz
 24 V DC
- 8.3: HEA Ignitor Exciter Input voltage 110V AC + 10%,-15%, 50 Hz \pm 5 Hz
 240V AC + 10%,-15%, 50 Hz \pm 5 Hz
- 8.4: HEA Spark Rod Flexible Rigid
- 8.5: HEA Spark Rod Length ("A" Dim) 2390 mm (94") 2540 mm (100") 2920 mm (115")
When mounted with Spark Tip 3380mm (133") 3712 mm (146")
 2413 mm (95")
- 8.6: Electrical Enclosure for Solenoid Valve, Limit Switch, Excitor & Junction / Conduit Box Weather Proof Flame Proof Explosion Proof
- 8.7: Tubing Material SS (PVC sheathed) Copper (PVC sheathed)

- Denotes selection / Requirement

Special Contract requirement if any(attach separate sheet if required): --



9.0 Following drawing variants are to be submitted for approval.

- Variant No: 01: HEA Ignitor Assy; 5" stroke; A= 94" (2390 mm) Flexible spark rod.
- Variant No: 02: HEA Ignitor Assy; 5" stroke; A=100" (2540 mm) Flexible spark rod.
- Variant No: 03: HEA Ignitor Assy; 5" stroke; A=115" (2920 mm) Flexible spark rod.
- Variant No: 04: HEA Ignitor Assy; 5" stroke; A=133" (3380 mm) Flexible spark rod.
- Variant No: 05: HEA Ignitor Assy; 5" stroke; A=146" (3712 mm) Flexible spark rod.

- Variant No: 06: HEA Ignitor Assy; 8" stroke; A= 94" (2390 mm) Flexible spark rod.
- Variant No: 07: HEA Ignitor Assy; 8" stroke; A=100" (2540 mm) Flexible spark rod.
- Variant No: 08: HEA Ignitor Assy; 8" stroke; A=115" (2920 mm) Flexible spark rod.
- Variant No: 09: HEA Ignitor Assy; 8" stroke; A=133" (3380 mm) Flexible spark rod.
- Variant No: 10: HEA Ignitor Assy; 8" stroke; A=146" (3712 mm) Flexible spark rod.

- Variant No: 11: HEA Ignitor Assy; 8" stroke; A= 94" (2390 mm) Rigid spark rod.
- Variant No: 12: HEA Ignitor Assy; 8" stroke; A=100" (2540 mm) Rigid spark rod.
- Variant No: 13: HEA Ignitor Assy; 8" stroke; A=115" (2920 mm) Rigid spark rod.
- Variant No: 14: HEA Ignitor Assy; 12" stroke; A= 95" (2413 mm) Rigid spark rod.



Part II B – Data sheet confirmation by Vendor.

Variant no selected as per Clause 9.0 : 09

BHEL Specification		Suppliers' confirmations
1.HEA RETRACTOR ASSY.		
1.1.0 AIR CYLINDER		
1.1.1.0 Make	*	
1.1.1.1 Part No / Model No.	*	
1.1.1 Bore	38-40 mm	
1.1.2 Gaiter	To be Provided	
1.1.3 Stroke Length		
Stroke Length = 127 mm (5")	<input type="checkbox"/> Part No. / Model No.	
Stroke Length = 203 mm (8")	<input checked="" type="checkbox"/> Part No. / Model No.	
Stroke Length = 305mm (12")	<input type="checkbox"/> Part No. / Model No.	
1.1.3 Construction	Heavy Duty	
1.1.4 Working Temp (Min.)	85° C	
1.1.5 Air Pressure Min/Max	3 to 7 Kg/ cm ² (g)	
1.1.6 Advance /Retract time Adjustable	2 to 5 Sec.	
1.1.7 Shaft Diameter	*	
1.1.8 Material		
Body	Aluminium	
Shaft	Stainless Steel	
Piston	Aluminium	
O Ring	Viton	
1.1.9 Pressure Port Connection	1/4" NPT	
1.1.10 Retractor mounting	4 holes dia 13.5 mm on PCD 98.5 mm, Flange OD 127 mm.	
1.2.0 SOLENOID VALVE		
110V AC + 10%,-15%, 50Hz ± 5Hz	<input type="checkbox"/> Part No. / Model No.	
240V AC + 10%,-15%, 50Hz ± 5Hz	<input checked="" type="checkbox"/> Part No. / Model No.	
24 V DC	<input type="checkbox"/> Part No. / Model No.	
1.2.1 Make	*	
1.2.1.1 Part No / Model No.	*	
1.2.2 Style	Single Coil,2 Way 4 Port	
1.2.3 Coil Duty	Continuous	
1.2.4 Inrush / Hold-AC	*	
1.2.5 Inrush / Hold-DC	*	
1.2.6 Insulation	Class H	
1.2.7 Valve Cv	*	
1.2.8 Material		
Body	Stainless Steel / Aluminium	
Internals	Stainless Steel / Aluminium	
Seating	Viton O Ring	
1.2.9 Valve ends	1/4" NPT	
1.2.10 Enclosure	Weather proof -NEMA 4	
1.2.11 Working Temp (Min.)	85° C	
1.3.0 LIMIT SWITCHES	2 Number	
1.3.1 Make	*	
1.3.1.0 Part No / Model No.	*	
1.3.2 Contacts	DPDT/ 2 CKT DOUBLE BREAK	
1.3.3 Rating	240 VAC,10 Amps	
1.3.4 Enclosure	Weather proof -NEMA 4	
1.3.5 Working Temp (Min.)	85° C	
1.4.0 JUNCTION BOX		



**FUEL SYSTEM
PE (BOILERS)**

TOS: 1930 / REV : 02

Page | 9 of 10

(with terminal block)		
1.4.1 Enclosure	Weather proof -NEMA 4	
1.4.2 Conduit Entry	22.2 mm Hole	
2.0.0 IGNITOR EXCITER		
2.1.0 Make	*	
2.2.0 Input		
110V AC + 10%,-15%, 50Hz ± 5Hz	<input type="checkbox"/> Part No. / Model No.	
240V AC + 10%,-15%, 50Hz ±5 Hz	<input checked="" type="checkbox"/> Part No. / Model No.	
2.3.0 Output Voltage	* V DC / Vendor to specify	
2.4.0 No. of Sparks @ rated Voltage	Minimum Sparks / Sec. / Vendor to specify	
2.5.0 Discharge Time	6.3 μ Sec. / Spark / Vendor to specify	
2.6.0 Stored Energy	Minimum Joules / Vendor to specify	
2.7.0 Power at Tip (First loop) min.	* Kw / Vendor to specify	
2.8.0 Peak Power	*	
2.9.0 Working Temp (Min.)	75° C	
2.10.0 Duty	* Vendor to specify	
2.11.0 Enclosure	Weather proof -NEMA 4	
2.11.1 Conduit Entry	22.4 mm	
3.0.0 SPARK ROD		
Flexible	<input checked="" type="checkbox"/>	
3.1.0 Make	*	
3.1.1 Max. OD	15.9 mm	
3.1.2 Flex Section- To be Provided	900 mm	
3.1.3 Length 'A' dim (with tip)		
2390 mm (94")	<input type="checkbox"/> Part No. / Model No.	
2540 mm (100")	<input type="checkbox"/> Part No. / Model No.	
2920 mm (115")	<input type="checkbox"/> Part No. / Model No.	
3380 mm (133")	<input checked="" type="checkbox"/> Part No. / Model No.	
3712 mm (146")	<input type="checkbox"/> Part No. / Model No.	
2413 mm (95")	<input type="checkbox"/> Part No. / Model No.	
3.0.0 SPARK ROD		
Rigid	<input type="checkbox"/>	
3.2.0 Make	*	
3.2.1 Max. OD	15.9 mm	
3.2.2 Flex Section	Not required	
3.2.3 Length 'A' dim (with tip)		
2390 mm (94")	<input type="checkbox"/> Part No. / Model No.	
2540 mm (100")	<input type="checkbox"/> Part No. / Model No.	
2920 mm (115")	<input type="checkbox"/> Part No. / Model No.	
2413 mm (95")	<input type="checkbox"/> Part No. / Model No.	
3.4.0 Operating Voltage	* V DC	
3.5.0 Breakdown Voltage	* V DC	
3.6.0 Operating Temp.	540° C at Tip, 110° C at Retractor end	
3.7.0 Materials		
Tube	Stainless Steel	
Flex Section	Stainless Steel	
Pin / Socket	Nickel / Inconel	
Insulation of wire	Mica & Fibre glass	
Insulation of Socket	Ceramic	
3.8.0 Ceramic Insulator type	Non-rotating type	
4.0.0 SPARK TIP	180 mm Long	
4.1.0 Make	*	
4.1.1 Part No./ Model No.	*	
4.2.0 Operating Voltage	* V DC	



4.3.0 Tip life	10 ⁶ sparks	
4.4.0 Material		
Casing	SS 310	
Tip	*	
Coating	Semi conductive	
5.0.0 FLEX CABLE	Length = 3658±50 mm	
5.1.0 Make	*	
5.1.1 Part No/ Model No.	*	
5.2.0 Operating Voltage	* V DC	
5.3.0 Break down Voltage	* V DC	
5.4.0 Operating Temp.	110 ⁰ C	
5.5.0 Materials		
Insulation	*	
Armour	Braiding	
Outer Cover	PVC	
6.0.0 INSPECTION & TEST		
6.1.0 Test Certificates		
6.1.1 Enclosure certification for Exciter box	Vendor to provide	
6.1.2 Enclosure certification for Junction box	Vendor to provide	
6.1.3 Dry Heat Damp Recycling Test as per IEC:68-2-30 for Excitor components	Vendor to provide	
6.1.4 Tip Life in 650 Deg C test furnace	Vendor to provide	
6.1.5 Spark rate at specified voltage	Vendor to provide	
6.1.6 First loop power	Vendor to provide	
6.2.0 Work Test Certificates		
6.2.1 Insulation Test for excitor flexible cable and spark rod	Min. 5 M Ω	
6.2.2 Dielectric Test	7500 VDC for 50 Sec.	
6.2.3 For working of Exciter & Retractor	Vendor to provide	
7.0.0 PACKING	<input checked="" type="checkbox"/> Seaworthy <input type="checkbox"/> Landworthy	
8.0.0 GUARANTEE	12Months from commissioning or 18 Months from supply: whichever is earlier	
9.0.0 REF.DOCUMENTS / DRGS		
9.1.0 HEA Ignitor Assy.	Vendor to provide	
9.2.0 Retractor Assy.	Vendor to provide	
9.3.0 Air Cylinder	Vendor to provide	
9.4.0 Solenoid Valve	Vendor to provide	
9.5.0 Limit Switch	Vendor to provide	
9.6.0 Exciter	Vendor to provide	
9.7.0 Spark Rod	Vendor to provide	
9.8.0 Spark Tip	Vendor to provide	
9.9.0 Circuit Drg/ Wiring diagram	Vendor to provide	
10.0.0 Special contract req. if any	-NIL-	

* Vendor to specify

56400-009-14-3
DRAWING NO

FOR TOLERANCES OF UNTOLERANCED
DIMENSIONS DURING MANUFACTURE
REFER PLANT STD.NO TP 023 0299

RETRACTED POSITION

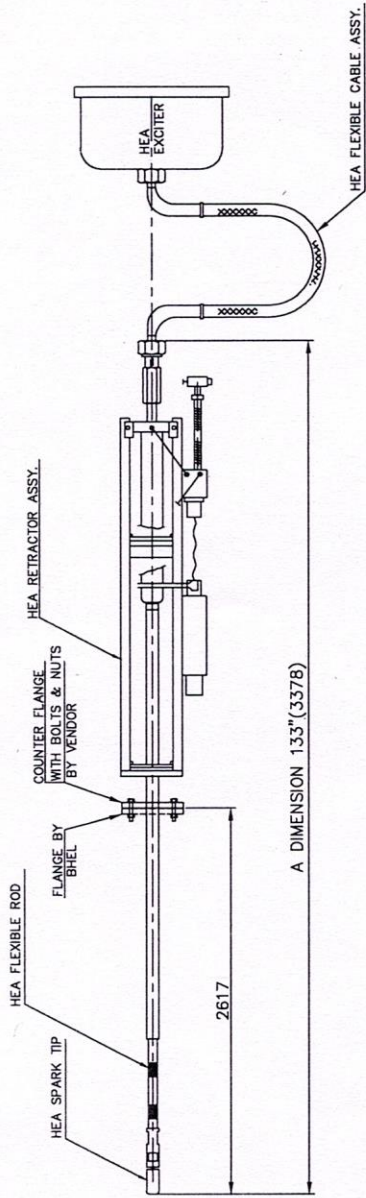

EXTENDED POSITION

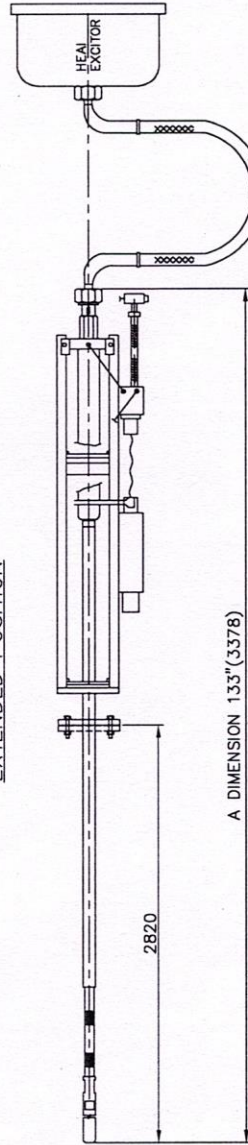

TYPE OF PRODUCT
OR NAME OF
CUSTOMER/PROJECT

WIDTH=32" DEPTH=2462MM



Bharat Heavy Electricals Ltd
UNIT: HIGH PRESSURE BOILER PLANT
TIRUCHIRAPALLI - 620014

DRN	M VENKATESWARLU	SIGNATURE	-sd-	DATE	24.02.2014
CHD	G SARAVANAKUMAR	SIGNATURE	-sd-	DATE	24.02.2014
APPD	M THANDAPANI	SIGNATURE	-sd-	DATE	24.02.2014

DEPT (FB)
CODE 129

WEIGHT (Kg)

REF TO ASSY / OLD DWG

ALL DIMENSIONS
ARE IN MM

SCALE
N.T.S

PROJECTION
SCALE

REF TO ASSY / OLD DWG

REV	DATE	ALTERED :
01		CHD & APPD:
		ZONE

DRAWING NO :
3-41-500-00795

TITLE
HEA IGNITOR DISPOSITION

REV
00

CAUTION: The information on this document is the property of BHARAT HEAVY ELECTRICALS LTD. It must not be used directly or indirectly in any way detrimental to the interest of the company.

TAMIL NADU GENERATION AND DISTRIBUTION CORPORATION LIMITED (TANGEDCO)

NAME OF THE PROJECT: 2X660 MW UDANGUDI SUPERCRITICAL THERMAL POWER
PROJECT STAGE – I, UDANGUDI, THOOTHUKUDI DISTRICT,
TAMIL NADU – 628215.

NAME OF THE EPC CONTRACTOR: M/s. BHEL, NEW DELHI.

SUB VENDOR APPROVAL FORMAT

1	Description of the system / package:	
2	Supply of Materials / Erection / Civil Works	
3	Approx. value of the supply / work (Rs. lakhs)	
4	Name of Sub Vendor(s) Proposed, with Address: a) b) c) d)	
5	Whether the proposed sub vendors have supplied similar materials or done similar works during the past 3 years (technical experience) (Encl. Copy of P.O/ Work Order)	
6	Annual financial turnover during the past 3 years (Encl. Copy of 3 years audited balance sheet).	
7	Whether any of the proposed sub-Vendors have been blacklisted by any State / Central Govt. Departments.	
8	Specific Recommendation of the EPC Contractor.	

Date:

Signature of the EPC contractor, with seal.

To,

The Chief Engineer / Projects II,
TANGEDCO Head Quarters
1st Floor, New EB Qtrs.
144, Annasalai, Chennai-2.
Email: cecpr2@tnebnet.org
Phone: 044-28515511
Mobile: 9445994289